

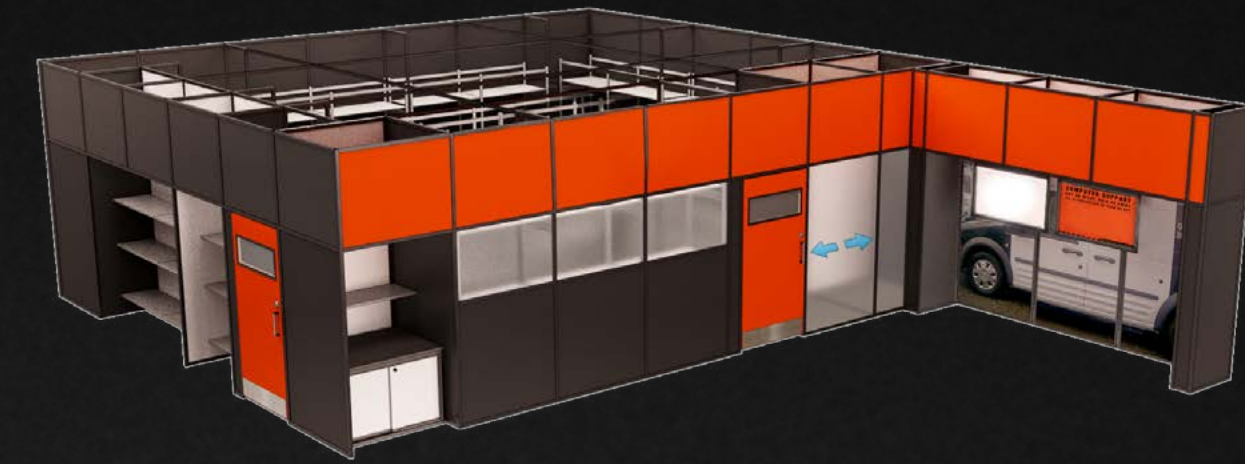

# I N T R O

- Punk rock music was born out of punk rock bands rejected perceived excesses of mainstream 1970s rock.
- Typically use short or fast-paced songs, with hard-edged melodies and singing styles, stripped-down instrumentation, and often political, anti-establishment lyrics.
- As history is known to repeat itself in one form or another, we see the same change happening in retail today.
- Increase of customers buying products on-line
- Many retailers noticing a decrease in in-store traffic
- In order to lure back customers in store, retailers offer free in-store pick up or additional client services such as free in-store exchanges.

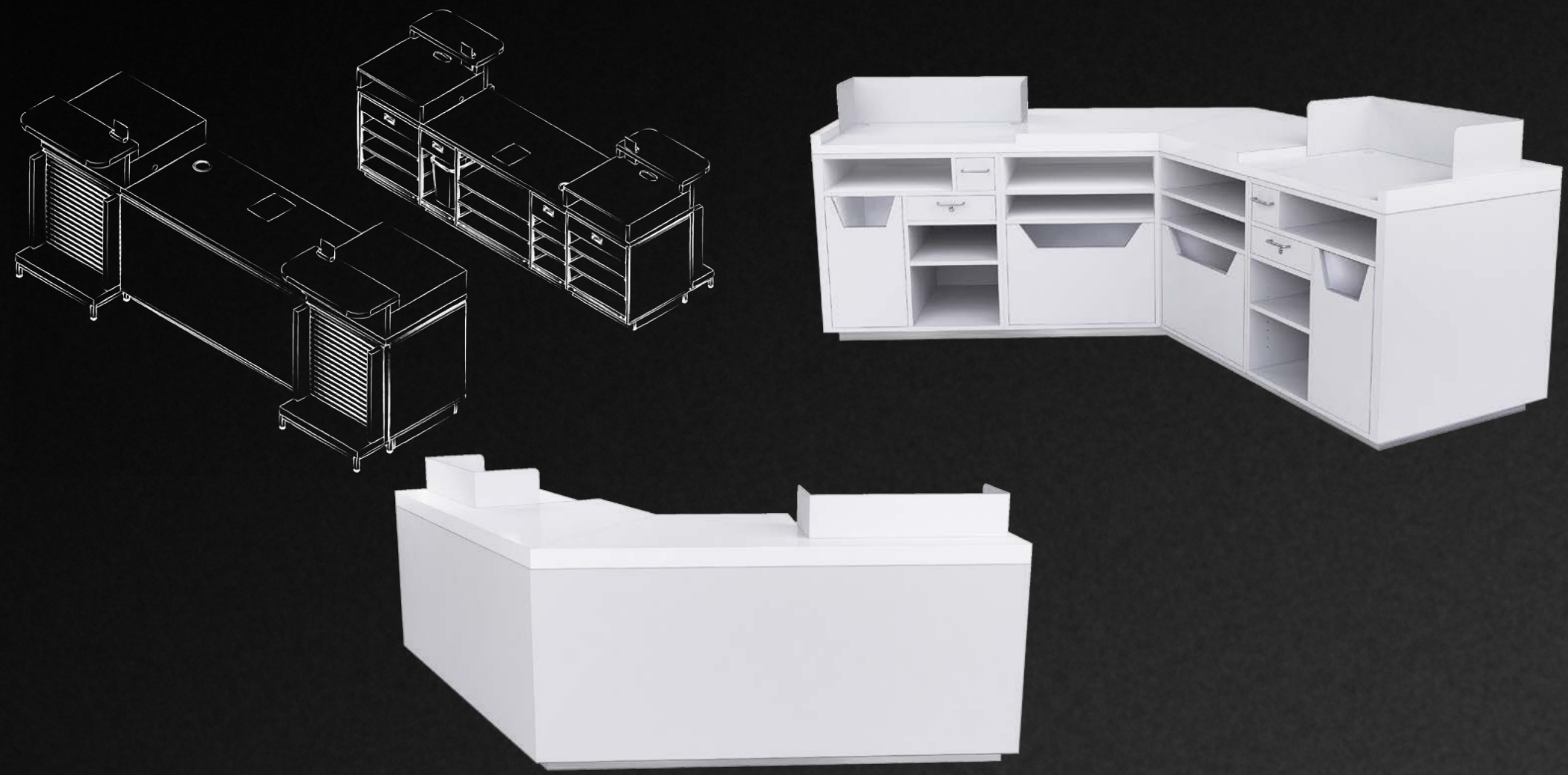



ALWAYS TRYING TO FIND CREATIVE WAYS TO SOLVE TODAY'S EVER CHANGING IN-STORE ISSUES, ARTITALIA GROUP HAS DESIGNED AND CREATED A MODULAR SYSTEM OF "ESSENTIAL IN-STORE ELEMENTS" TO SERVE THE EVER CHANGING NEEDS OF TODAY'S IN-STORE ENVIRONMENT.



THE RETR-FIT



~~METALS~~  
DEAD

T R A C K 0 1

# THE "MODULAR CASH WRAP" THRASH

- Cash wraps are built in modular sections and using same concept as gondola run
- Cash wraps are developed to accept a variety of customizable accessories
- Customizable countertops such as solid surface, laminate, RTF all with various color options
- Customizable front and side wood panels
- Customizable length
- Unique quick connecting system
- Metal shroud to protect cash register/PC
- Patented extruded metal structure
- Patented wire management system

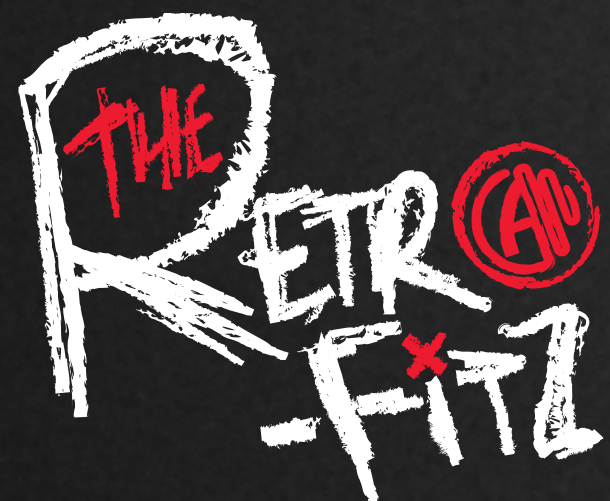

# 01 THE "MODULAR CASH WRAP" THRASH

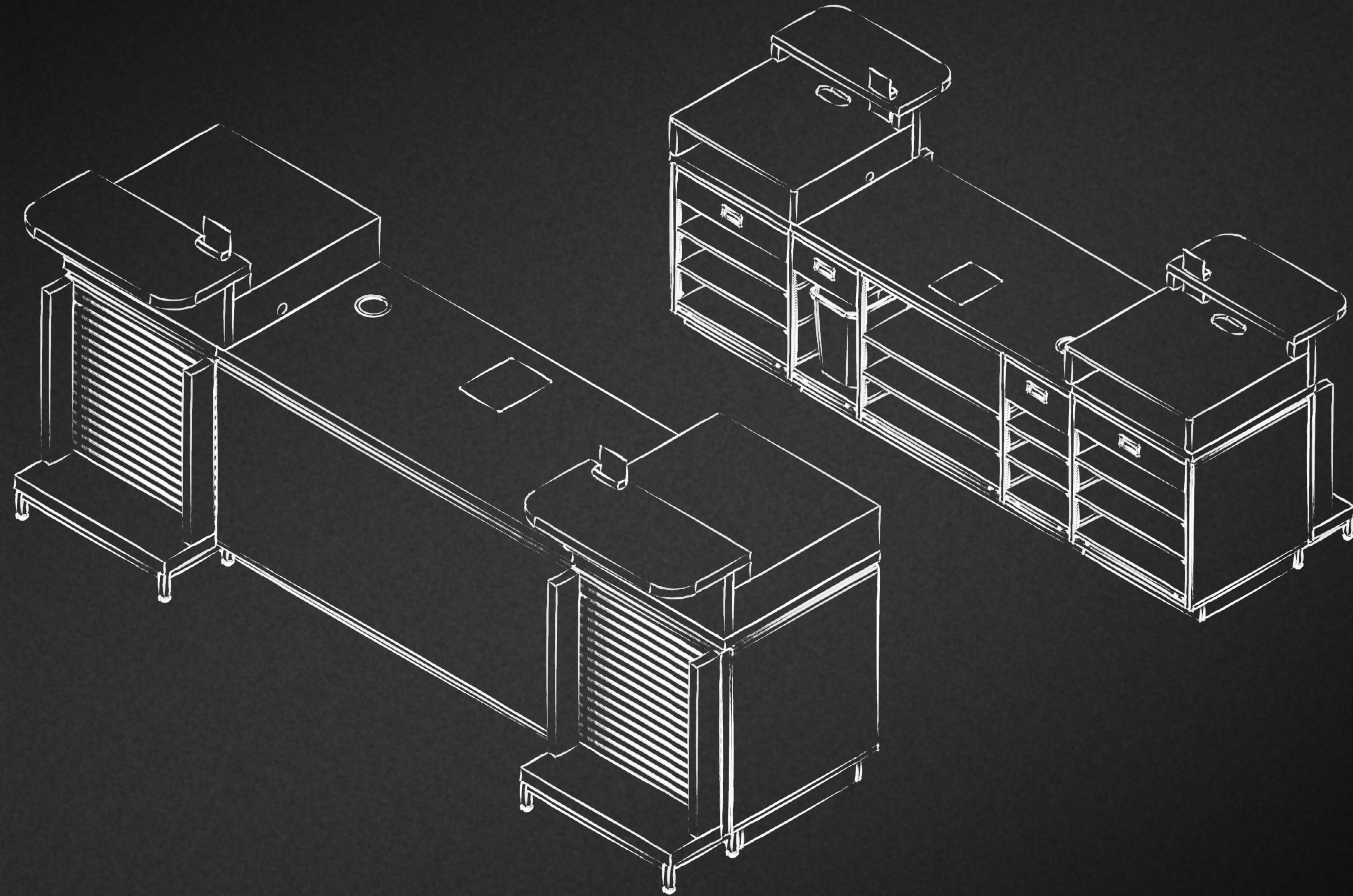

# 01 THE "MODULAR CASH WRAP" THRASH

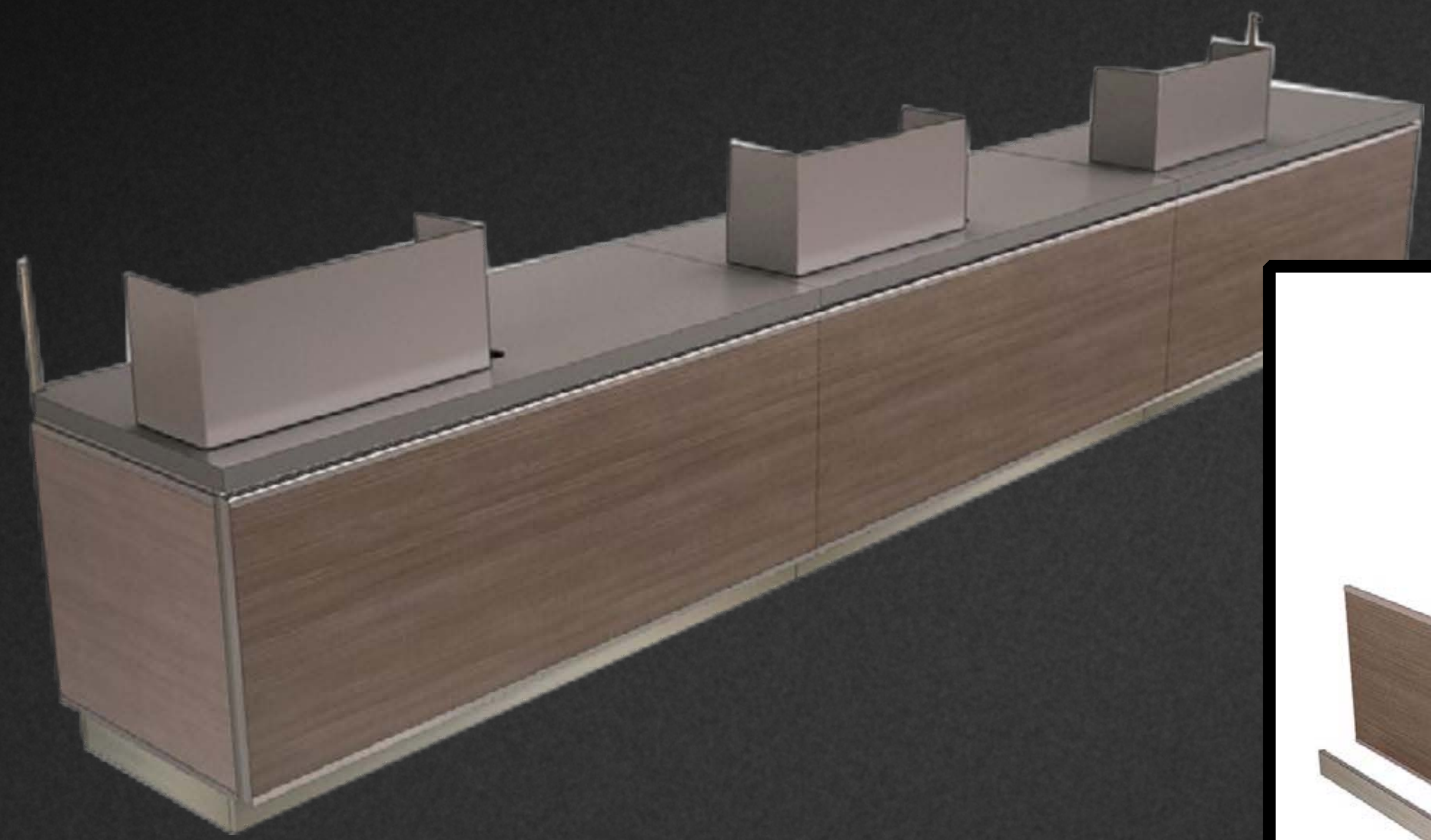

# 01 THE "MODULAR CASH WRAP" THRASH

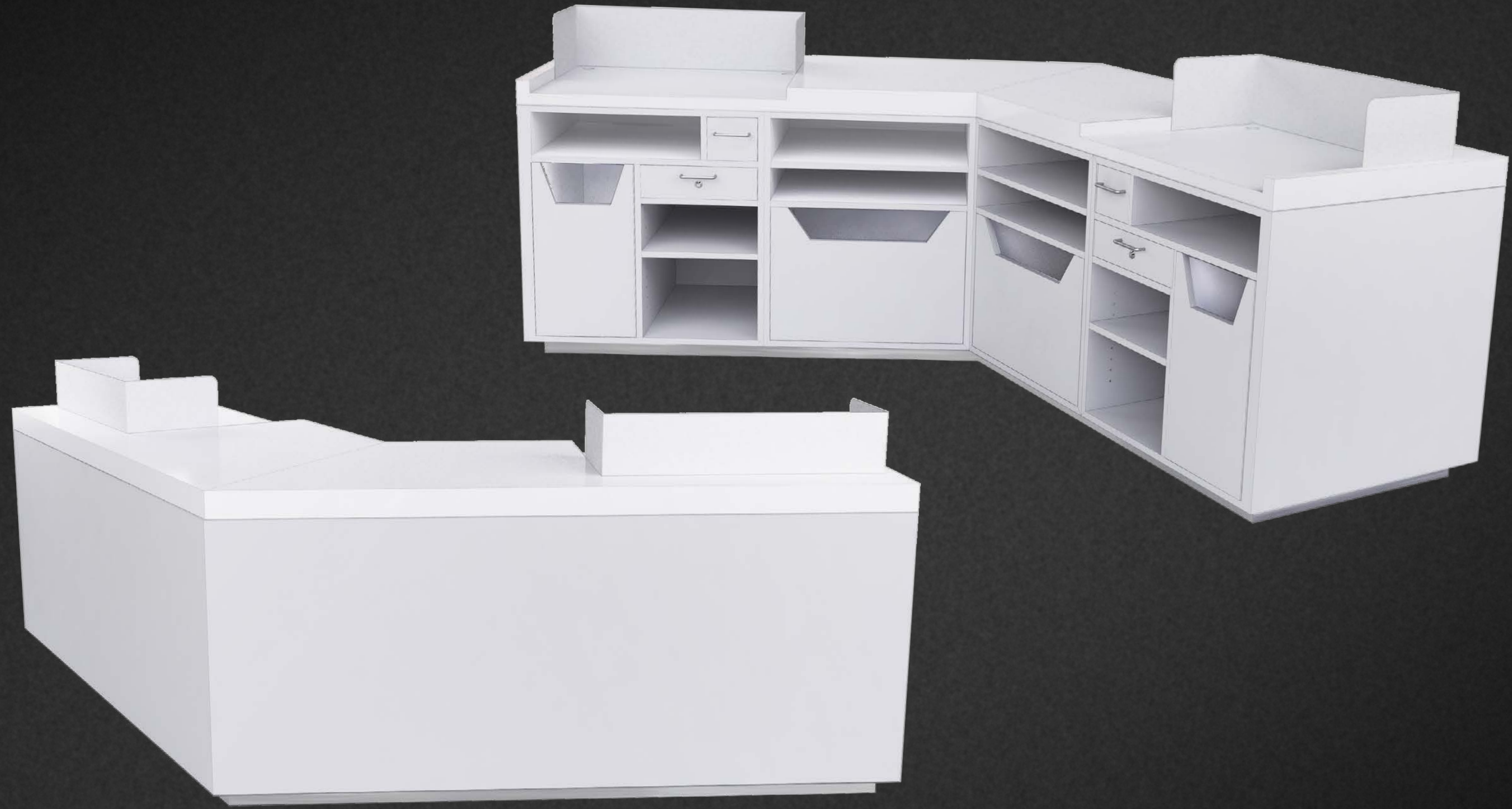



# 01 THE "MODULAR CASH WRAP" THRASH

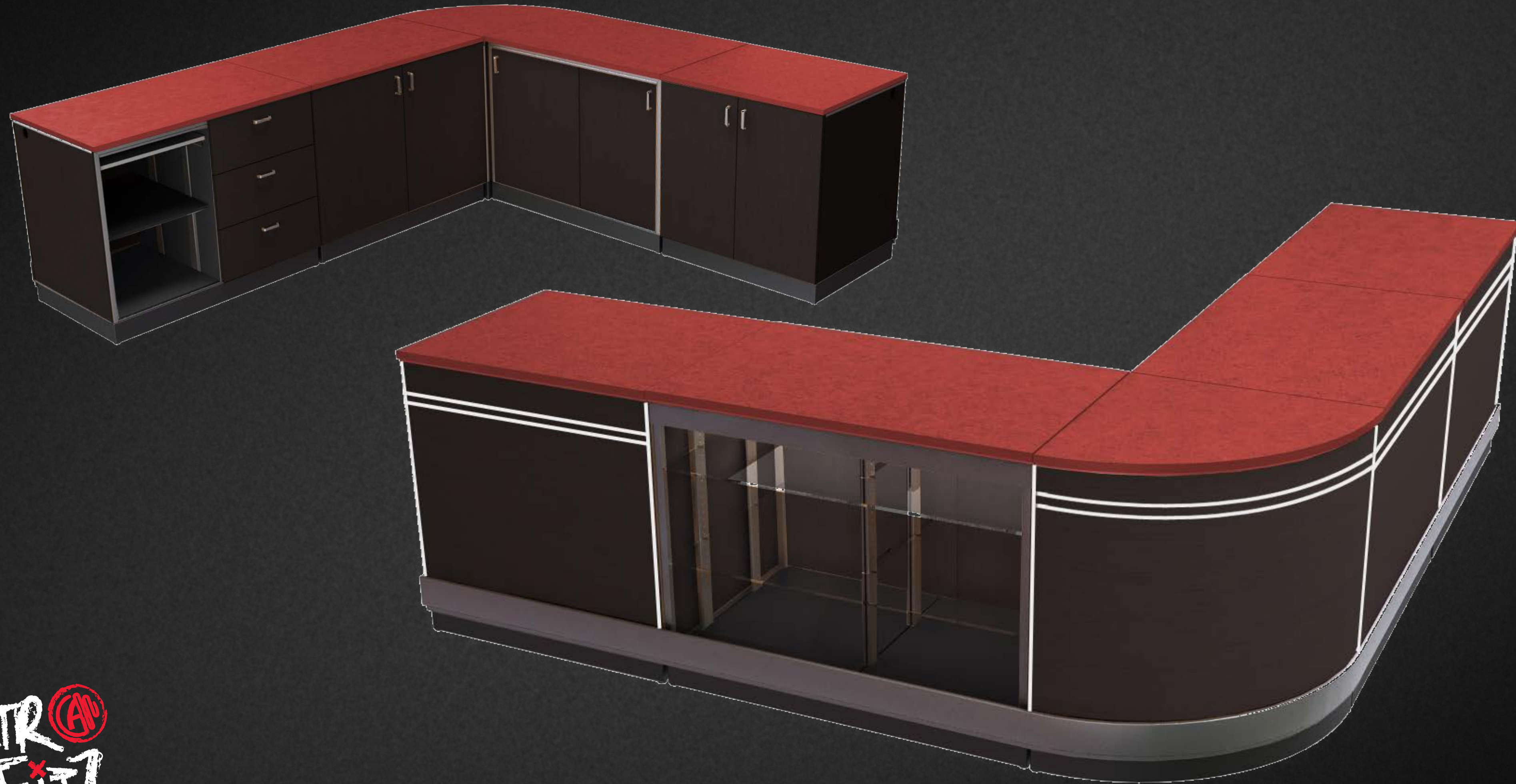

# 01 THE "MODULAR CASH WRAP" THRASH





RETAIL'S  
DEAD



T R A C K 0 2

# THE "MODULAR WALL SYSTEM" SYMPHONY

- Quick to produce, ship, deliver and install!
- Slotted uprights allow for merchandising or storage inside and out
- Customizable colors and finishes
- Customizable in both height and length
- System can be expanded after entire system is installed
- Can be taken down and assembled quickly and easily
- Multiple accessories are available such as shelves, fitting room bench, face outs, hang bars, mirrors, etc.
- Easy to transport, install and to relocate
- Sturdy Construction (Seismic Approved).



# 02 THE "MODULAR WALL SYSTEM" SYMPHONY



# 02 THE "MODULAR WALL SYSTEM" SYMPHONY



THE  
RETR  
-FITZ

# 02 THE "MODULAR WALL SYSTEM" SYMPHONY



THE  
RETR  
FITZ

# 02 THE "MODULAR WALL SYSTEM" SYMPHONY

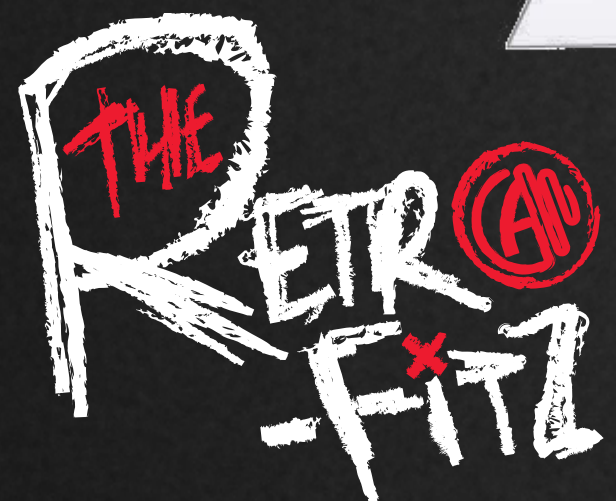
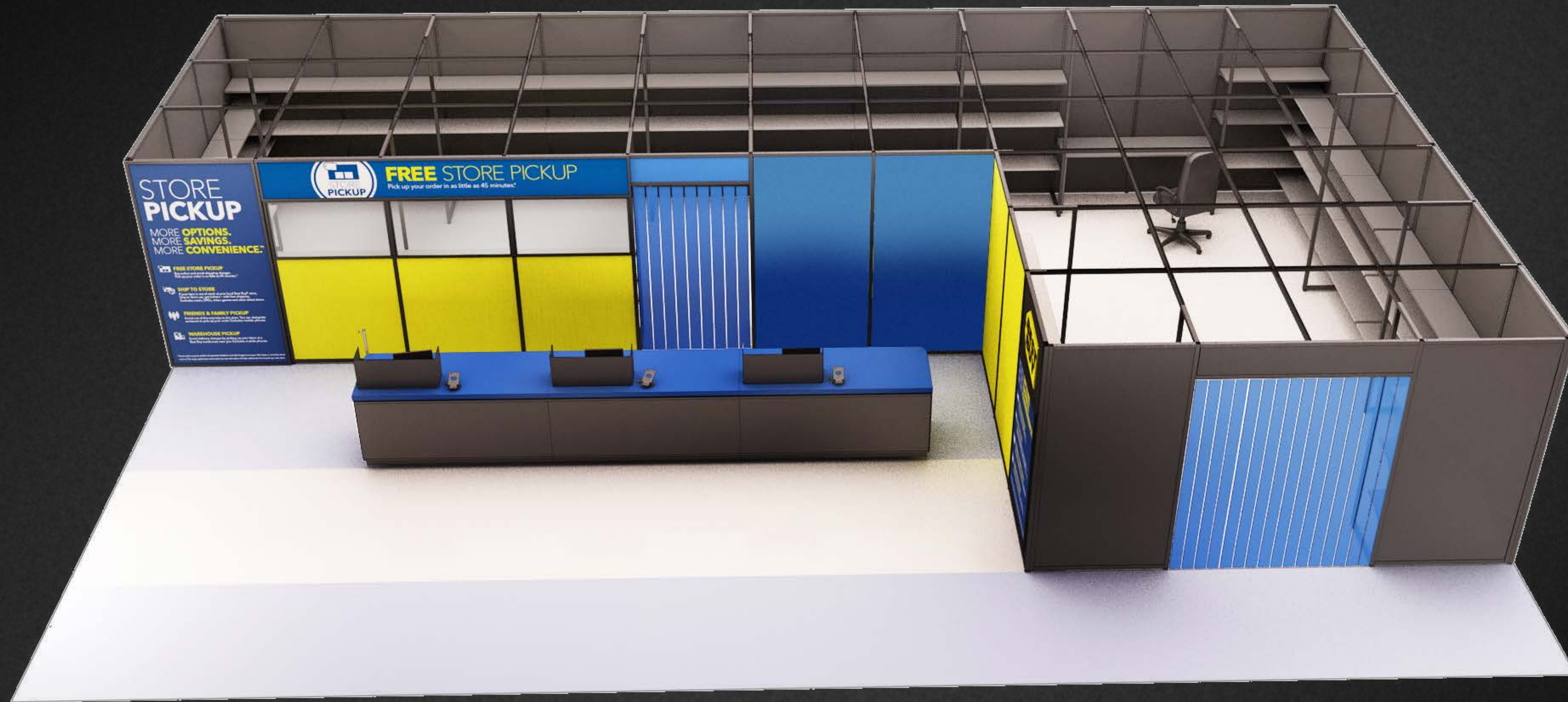



# 02 THE "MODULAR WALL SYSTEM" SYMPHONY

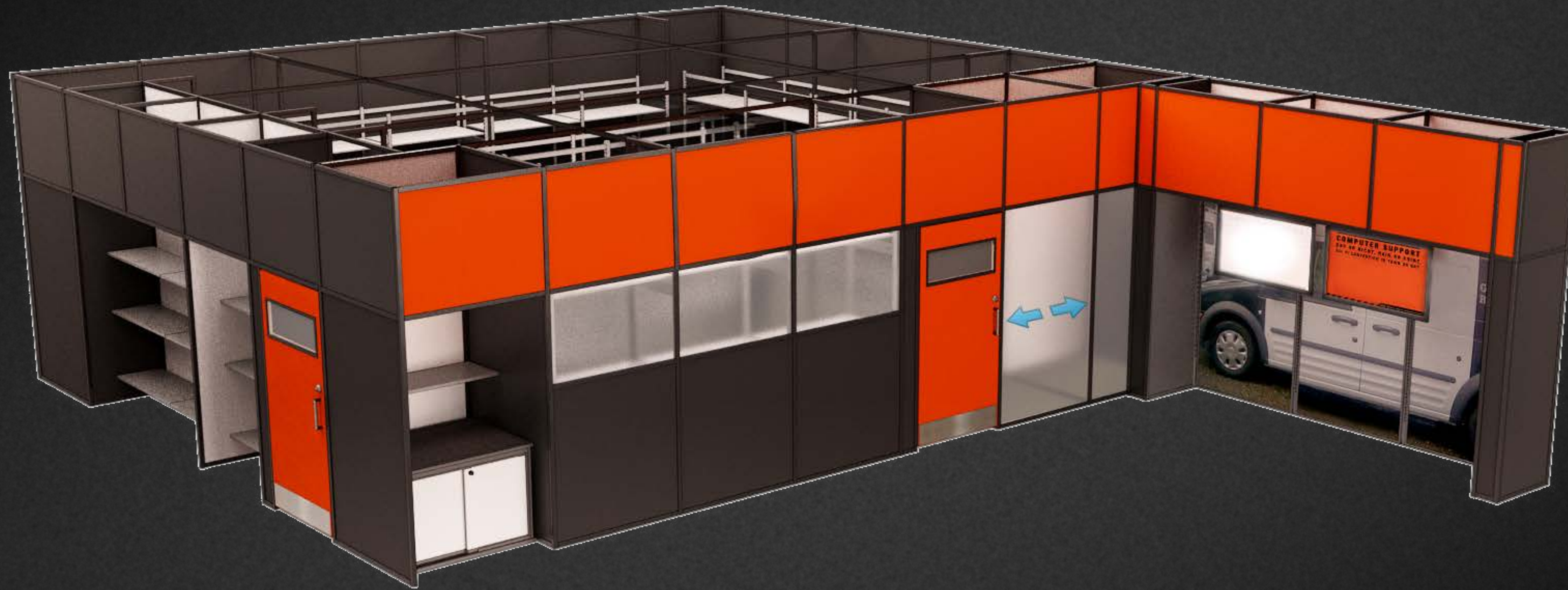

THE  
RETR  
FITZ



T R A C K 0 3

# THE "POP-UP STORE" W/ DISTORTION

INCLUDES

- Fitting Room
- Cash Desk
- Wall Unit with shelving
- Hang Racks
- Mobile Clothing Carts
- Mobile unit with shelving used for transporting merchandise



# 03 THE "POP-UP STORE" W/ DISTORTION



# 03 THE "POP-UP STORE" W/ DISTORTION



# 03 THE "POP-UP STORE" W/ DISTORTION

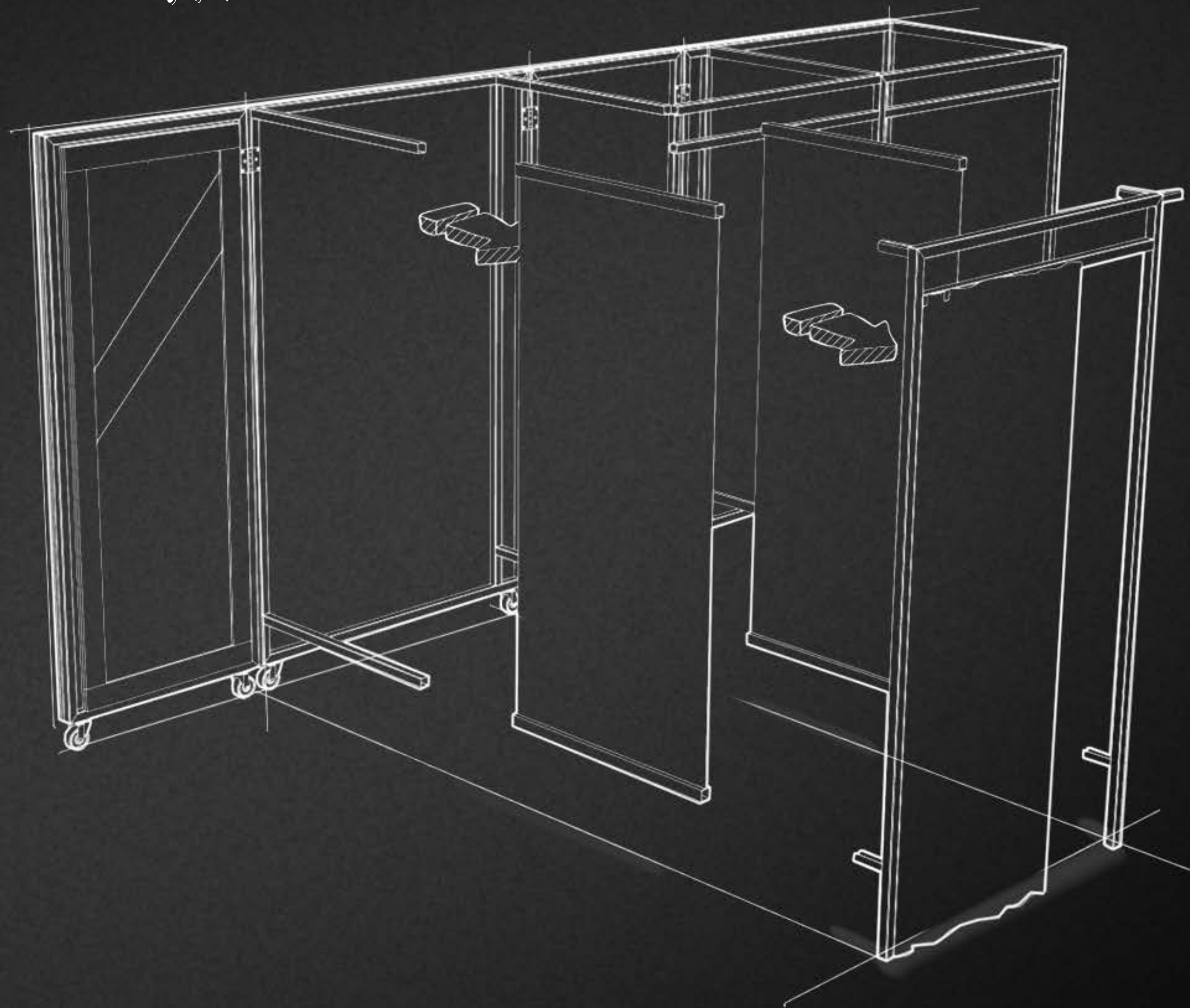
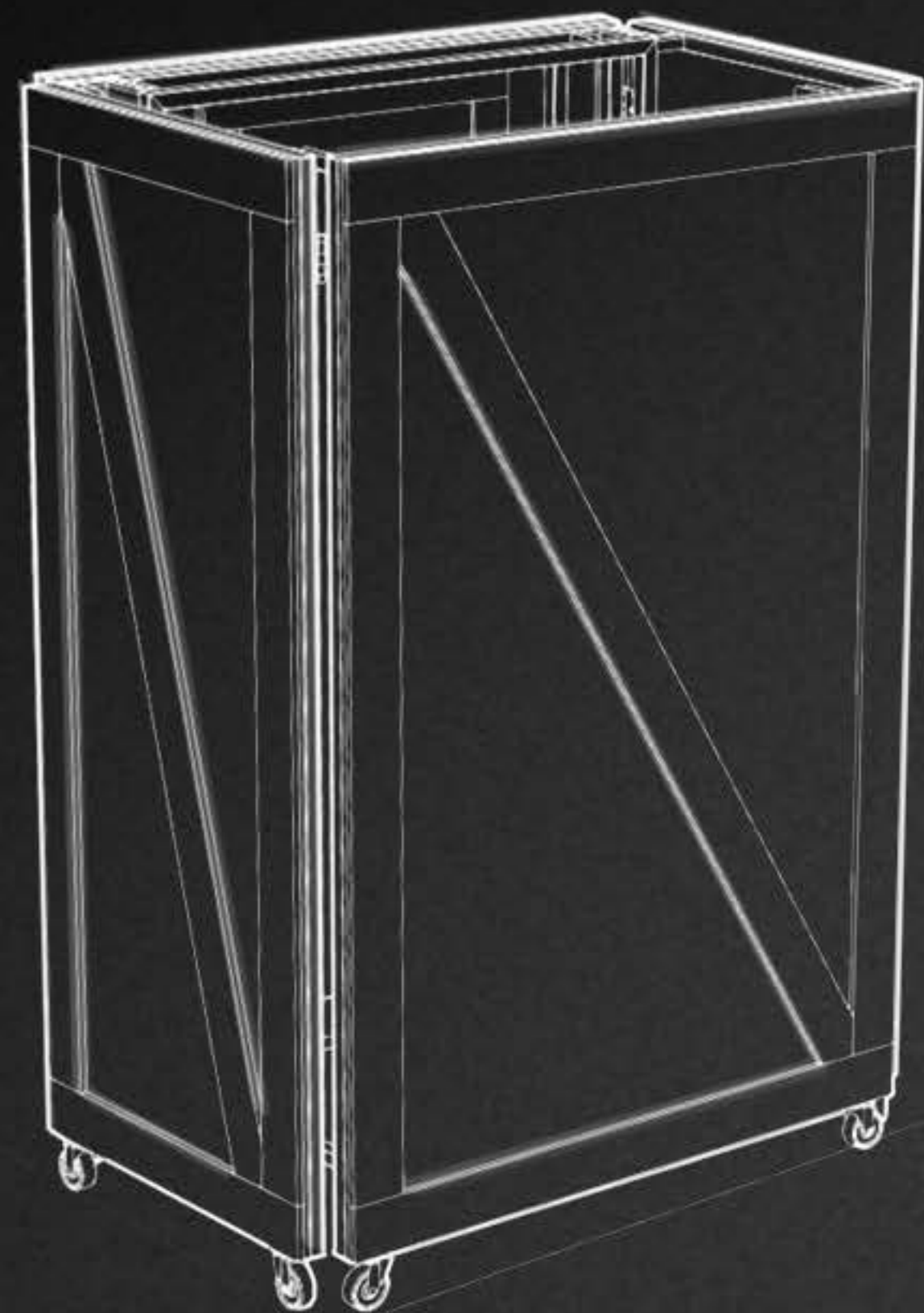

# 03 THE "POP-UP STORE" W/ DISTORTION



THE  
RETR  
-FITZ

# 03 THE "POP-UP STORE" W/ DISTORTION



THE  
RETR  
FITZ



# 03 THE "POP-UP STORE" W/ DISTORTION

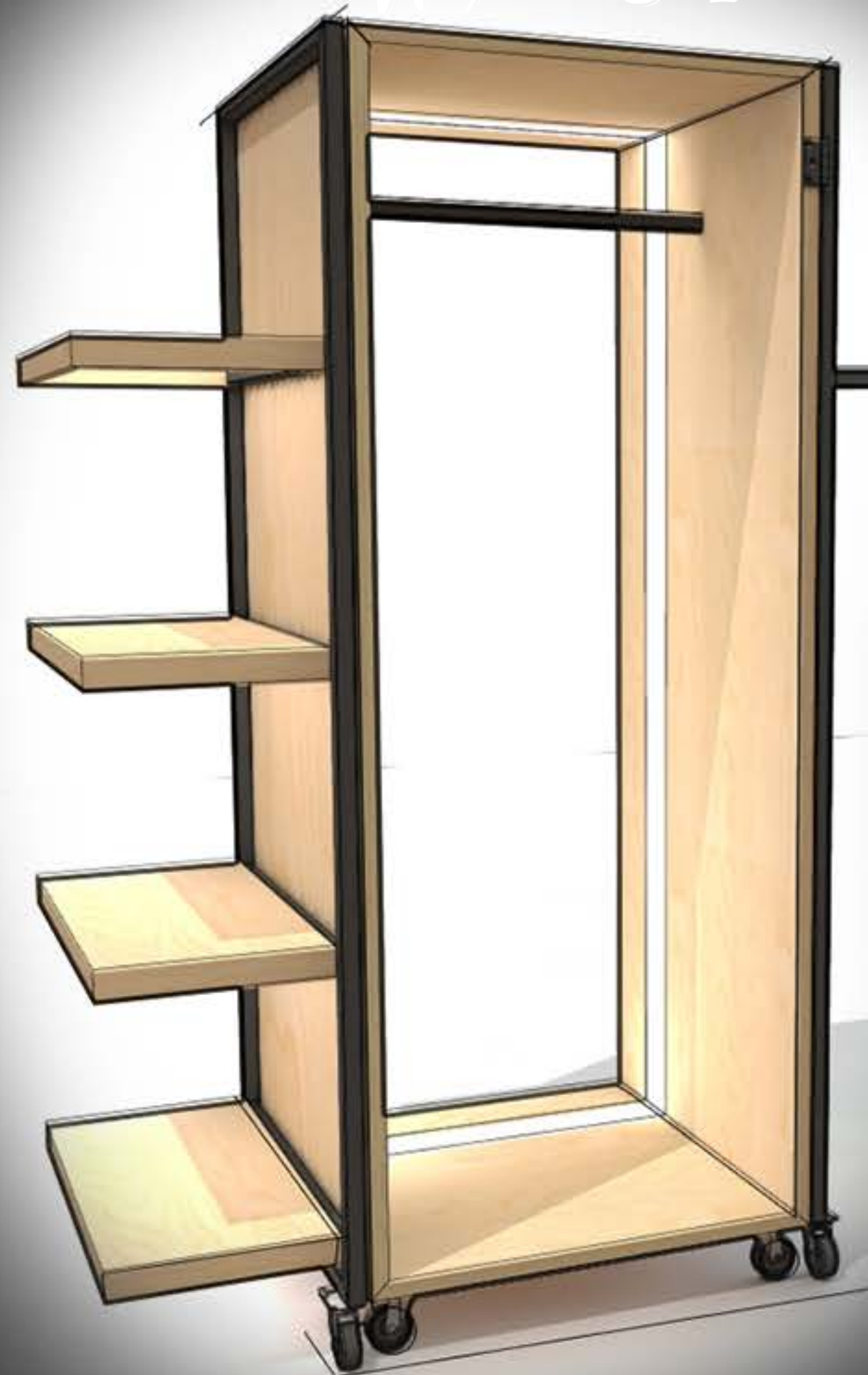

THE  
RETR  
FITZ

# 03 THE "POP-UP STORE" W/ DISTORTION

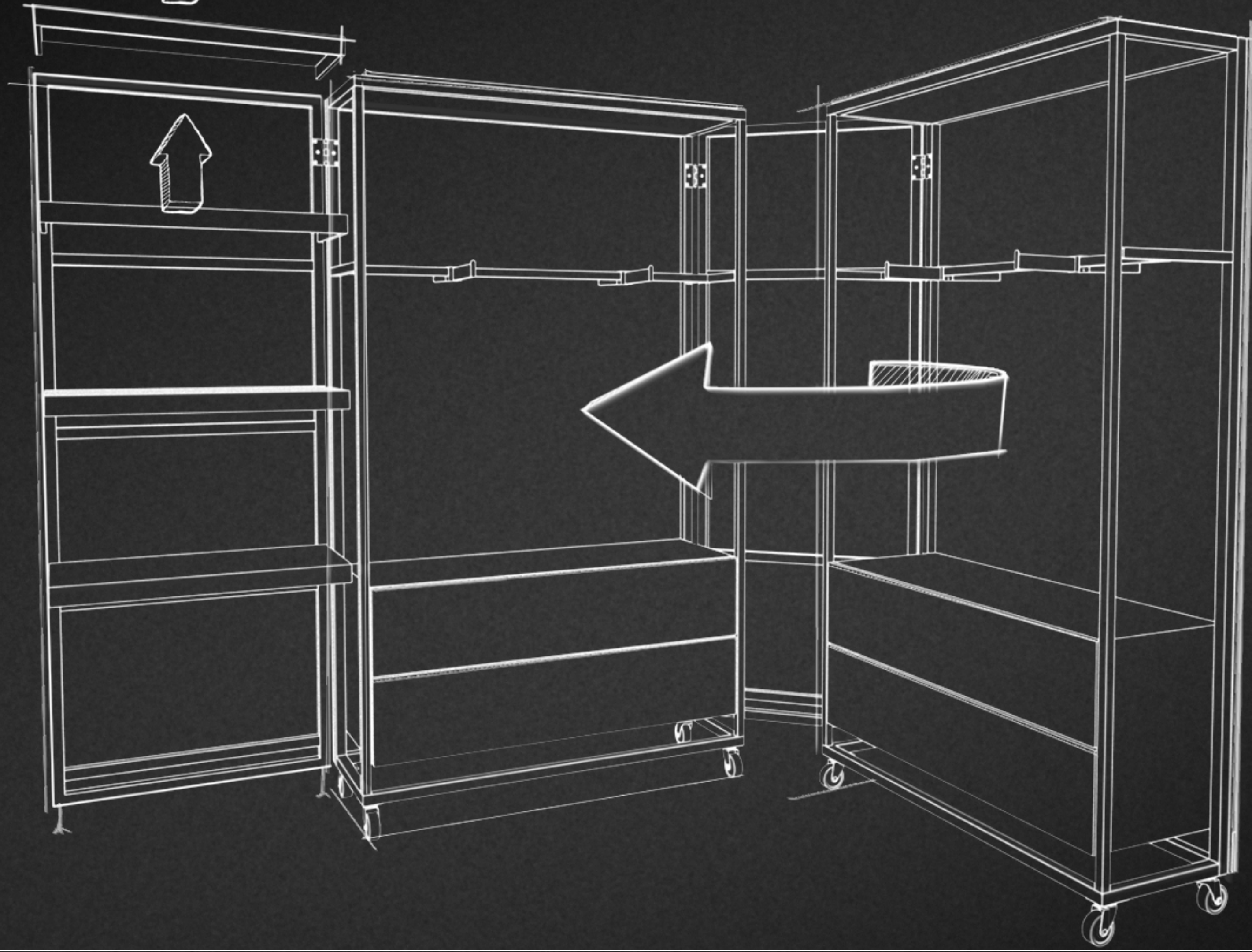

THE  
RETR  
FITZ

# 03 THE "POP-UP STORE" W/ DISTORTION



THE  
RETR  
FITZ

# 03 THE "POP-UP STORE" W/ DISTORTION

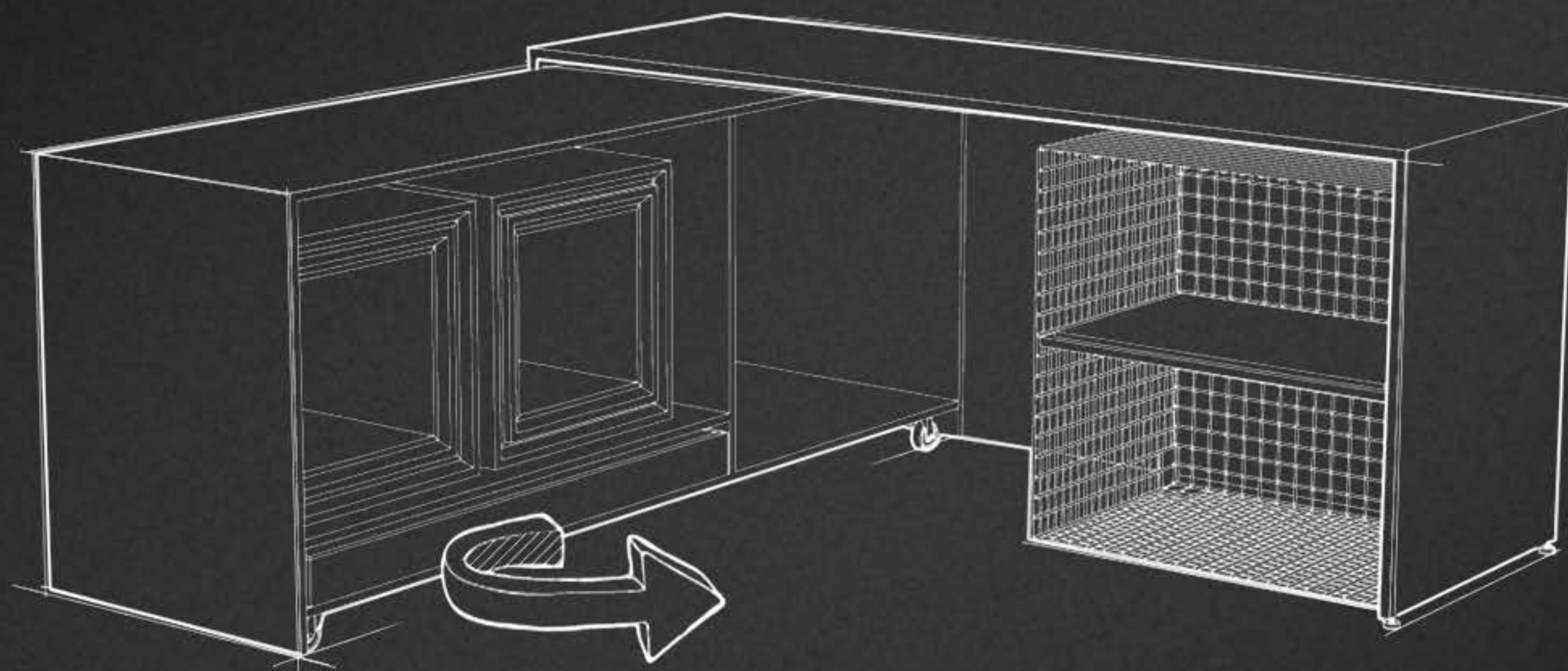

THE  
RETR  
FITZ

# 03 THE "POP-UP STORE" W/ DISTORTION



THE  
RETR  
FITZ



555H  
SERIES II

T R A C K 0 4

# THE "E-PARCEL LOCKER AND THE PUNK ROCKER"

- Accessible 24 hrs, 7 days/wk.
- Integrated touch screens and digital signage to replace existing ad boards
- Can be used as a return, refund, and exchange center thus increasing sq. footage in-store.
- Customizable colors and finishes
- Customizable in both height and length
- Customizable door sizes depending on the size of your standard packaged products
- Patented anti-theft design



# 04 THE "E-PARCEL LOCKER AND THE PUNK ROCKER"

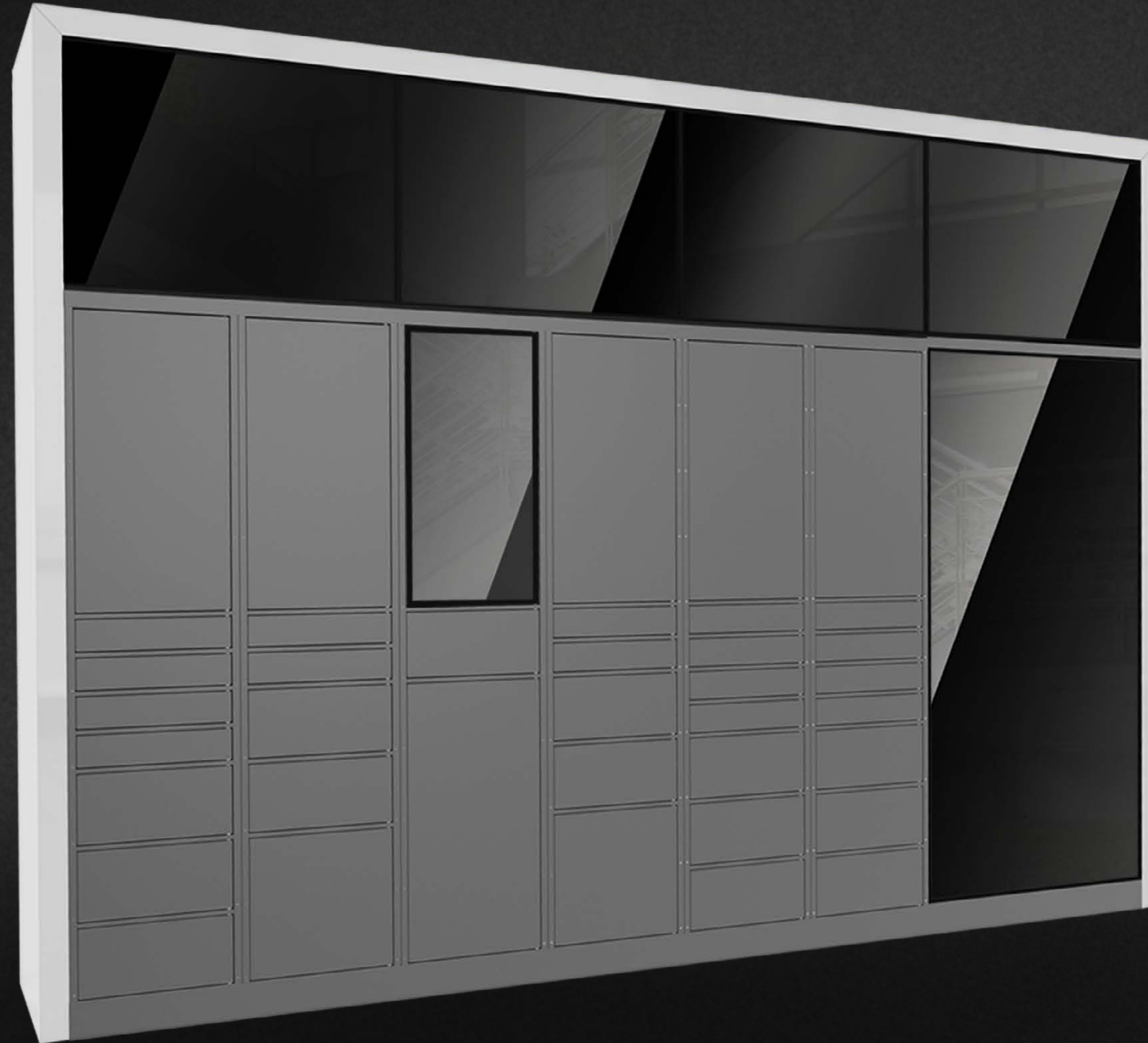



# 04 THE "E-PARCEL LOCKER AND THE PUNK ROCKER"



# 04 THE "E-PARCEL LOCKER AND THE PUNK ROCKER"



THE  
RETR  
-FITZ

# 04 THE "E-PARCEL LOCKER AND THE PUNK ROCKER"



THE  
RETR  
FITZ

