

HYGIENE SHIELDS FOR RESTAURANTS



SHIELDS FOR RESTAURANT TABLES

Safeguard for clients and
customer-facing associates.

PRODUCT SPECIFICATIONS:

- **Material:** Commercial grade clear polycarbonate and powder coated steel
- Clamps to existing tables
- Does not damage surfaces
- Custom sizing available
- Pricing on demand



DES-03656-01



DES-03656-02



DES-03656-03

DES-03656

STD HEIGHT: 24"

Email for pricing and lead times:
sales@artitalia.com

Sterilcoat: Germicidal Powder Coating available by request. Additional costs may apply.

INLINE DIVIDER PARTITION

Safeguard for clients and
customer-facing associates.

PRODUCT SPECIFICATIONS:

- **Material:** Commercial grade clear polycarbonate and powder coated steel
- 36"x36" shield
- Knockdown assembly
- Pricing on demand

DES-03649

W 36" | D 24" | H 72"

Email for pricing and lead times:
sales@artitalia.com



Sterilcoat: Germicidal Powder Coating available by request. Additional costs may apply.

3 SIDED COUNTERTOP SAFETY SHIELD

Safeguard for clients and
customer-facing associates.

PRODUCT SPECIFICATIONS:

- **Material:** Commercial grade clear polycarbonate
- Easy installation
- **Included with product:** Velcro and double-sided tape to allow for a semi-permanent installation
- Custom sizes available
- Pricing on demand

ART-PSS-2 | W 35" | D 17" | H 39"

Email for pricing and lead times:
sales@artitalia.com

ART-PSS-2

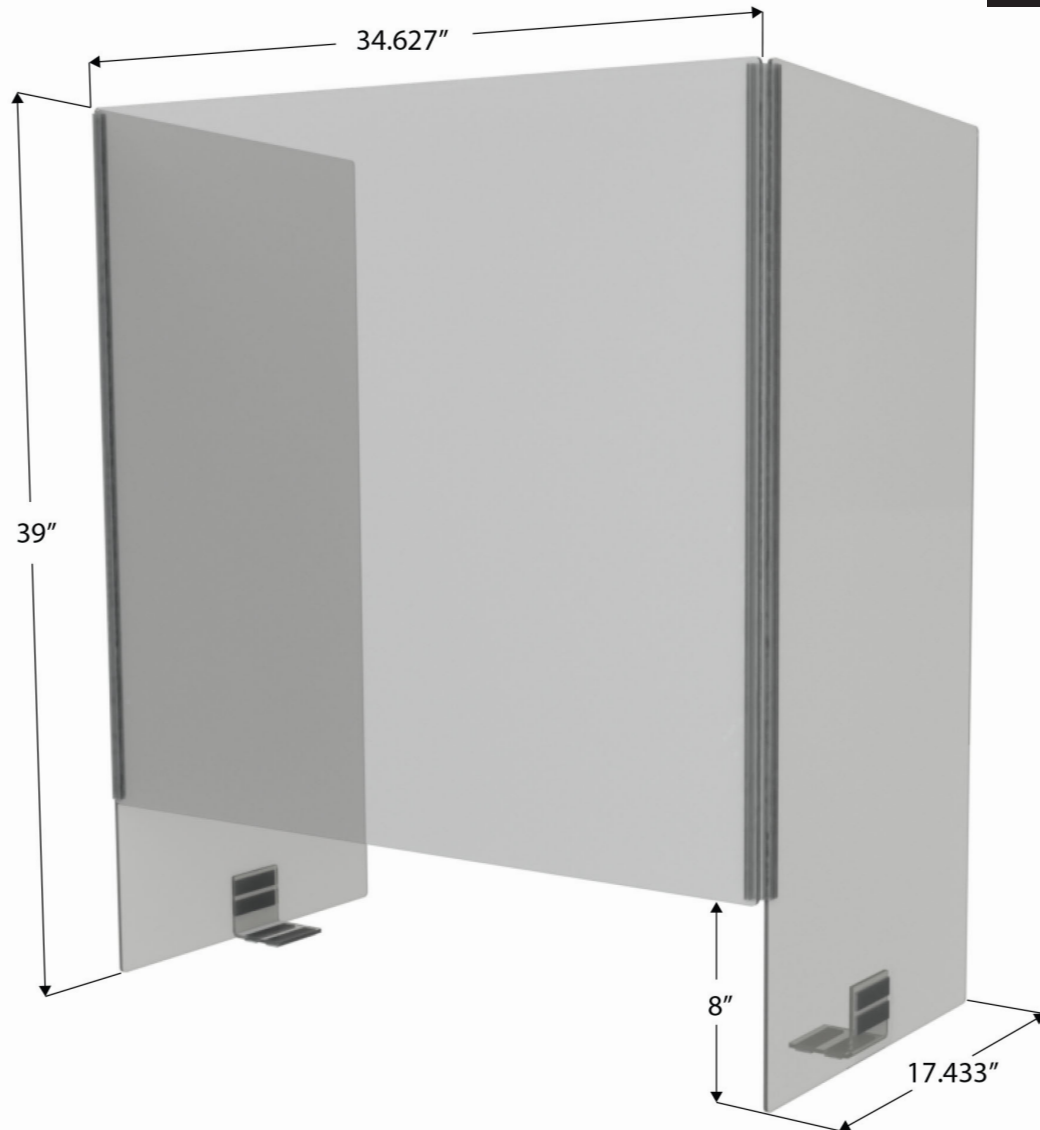

PARTITIONS FOR RESTAURANT KIOSKS

Safeguard for clients and
customer-facing associates.

PRODUCT SPECIFICATIONS:

- **Material:** Commercial grade clear polycarbonate and powder coated steel
- Adaptable for single or double sided kiosk variations
- Sanitizer and wipe dispensers
- Custom sizing available
- Pricing on demand

DES-03639

Sections: 48" x 48"

Email for pricing and lead times:
sales@artitalia.com



ONE-SIDED KIOSKS DES-03639-01



DOUBLE SIDED KIOSKS DES-03639-02

Sterilcoat: Germicidal Powder Coating available by request. Additional costs may apply.

HYGIENE SHIELDS FOR RESTAURANTS

Artitalia Group has designed and manufactured ideal restaurant solutions that not only provide the health and safety measures to help eliminate the spread of germs but a series of different hygiene shields that are perfect for any restaurant, café, cafeteria, or food outlet.

Shields for Restaurant Tables: Enjoy a meal with your family and friends all while keeping a safe distance from others with these customizable transparent partitions that are easy to install, contain germicidal plastic, powder coated steel, and can be used in a variety of locations.

Inline Divider Partition: The Inline Divider Partition can be installed between tables at restaurants, food courts, office spaces, and common areas. Made from clear Lexan and powder coated steel, this 36" x 36" shield is quick and easy to assemble and will provide the peace-of-mind you need—especially when it comes to the safety of your customers and associates.

3 Sided Countertop Safety Shield: The countertop top safety shield can be installed at the point of sale to help mitigate the spread of germs, protecting your clients and in turn your store associates.

Partitions for Restaurant Kiosks: Complete with sanitizer and wipe dispensers, and adaptable for single or double-sided kiosk variations, these partitions will help protect your customers all while they interact with your kiosk and finally put an end to their food cravings.